



FILTRATION



TANK MONITORING



HOSE REEL



ACCESSORIES



MERCHANDISE

PIUSI



ANY BIODIESEL



AIR



ANTIFREEZE



AdBlue®



BIODIESEL



DIESEL



FOOD



GASOLINE



GREASE



KEROSENE



OIL



WATER



WINDSCREEN

CHART

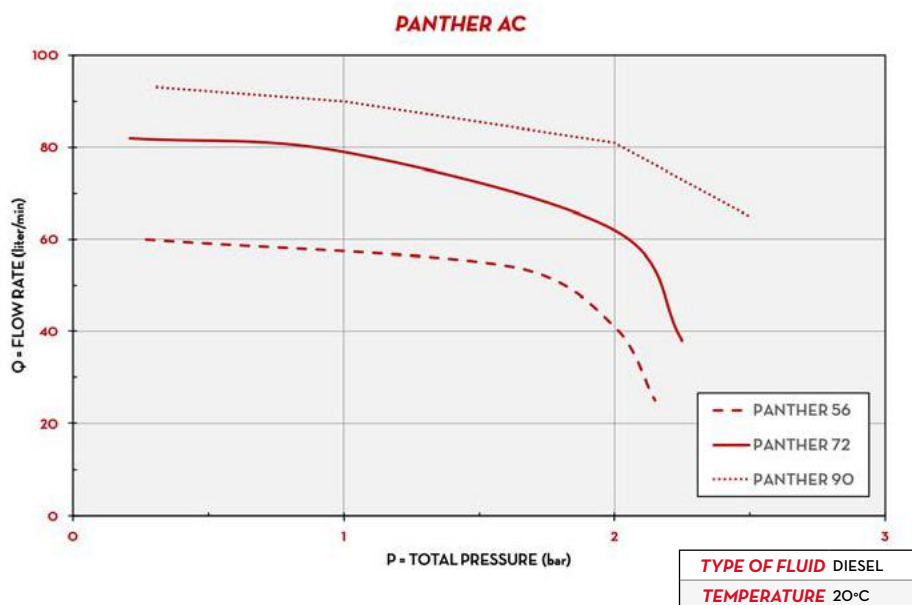

IN THE BOX

- PANTHER AC PUMP
- INSTRUCTION MANUAL

DETAILS



VANE ROTOR

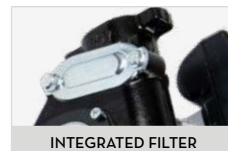

INTEGRATED FILTER

DIMENSIONS

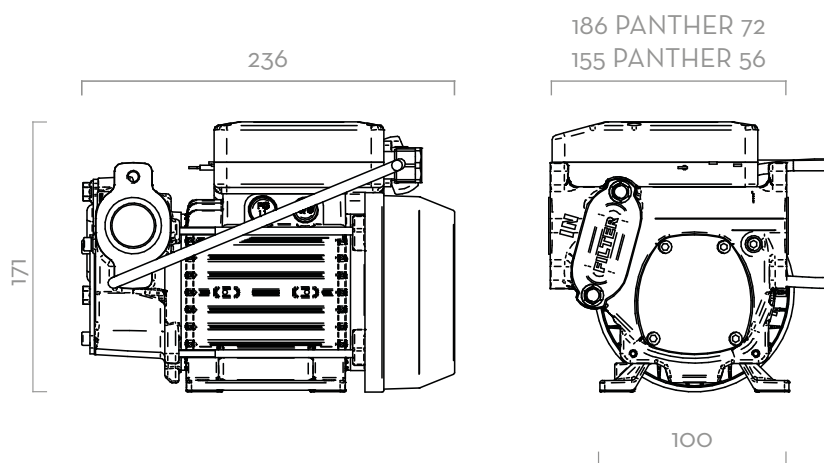

Dimensions expressed in millimeters

MATERIALS

- BODY: CAST IRON
- ROTOR: SINTERED STEEL
- VANES: TECHNOPOLYMER
- SHAFT: STEEL



PUMP

- MAX 6M (20FT),
- SUCTION HOSE Ø 1" MIN,
- MAX SUCTION HEIGHT:
- 2M (7FT) W/O NON RETURN VALVE
- 4M (14FT) W NON RETURN VALVE



TANK

TECHNICAL DATA

CODE	DESCRIPTION	FLUIDS TYPE	FLOW RATE		VOLTAGE				RPM	INLET OUTLET BSP	FLANGE CON- NECTION	BYPASS VALVE	INLET FILTER	DUTY CYCLE MINUTE	
			L/MIN	GPM	SINGLEPHASE MOTOR V./HZ	THREEPHASE MOTOR V./HZ	POWER WATT	AMP. MAX.							
PANTHER 56															
FO0730000	PANTHER 56 230/50	D	56	15	230/50	-	350	3	2900	1"	-	YES	YES		
000731000	PANTHER 56 230/60	D	70	18	230/60	-	500	3,9	3400	1"	-	YES	YES		
000733000	PANTHER 56 400/50	D	56	15	-	400/50	500	1,3	2900	1"	-	YES	YES		
PANTHER 72															
000732000	PANTHER 72 230/50	D	72	19	230/50	-	500	4,2	2900	1"	YES	YES	YES		
000735000	PANTHER 72 400/50	D	72	19	-	400/50	500	1,6	2900	1"	YES	YES	YES		
FO0732B00	PANTHER 72 230V/50HZ B100	B D	72	19	230/50	-	500	4,2	2900	1"	YES	YES	YES		
PANTHER 90															
FO073302A	PANTHER 90 230/50	D	90	23,8	230/50	-	700	4,9	2900	1"	YES	YES	YES	30	

UPON REQUEST IT IS AVAILABLE WITH DIFFERENT VOLTAGES AND 60 HZ FREQUENCY.
(*) EXCEPT PANTHER 90