



FUEL MANAGEMENT SYSTEMS



DISPENSERS



KITS



PUMPS



METERS



NOZZLES

EX100 DRUM

FEATURES

- CONTINUOUS DUTY
- THERMAL PROTECTION
- SUCTION UNIT WITH INTEGRATED FILTER
- BUILT-IN BYPASS VALVE
- UL VERSION AVAILABLE

PIUSI EX100 DRUM is the new transfer kit for flammable fluids that is characterized by a high flow rate and works with a continuous duty cycle. Simple to use, compact, versatile, it adapts to any working conditions: you can use it wherever you need it most. The PIUSI EX100 DRUM is ATEX certified and complies with the directives on the use of materials in potentially explosive atmospheres.

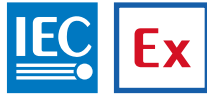

EX100 DRUM /A140/K150/5MT



EX100 DRUM /A140/5MT

PERFORMANCE

UP TO
100 L/MIN

FLOW RATE

AC
VOLTAGE

POWER



OUR PUMPS COMPLIES WITH THE FOLLOWING MARKING ATEX/IECEx

II	2	G	Ex	d	IIA	T4	Gb
GROUP	CATEGORY	TYPE OF EXPLOSIVE ATMOSPHERE	PERMANENT PREFIX	PROTECTION METHOD	GAS GLASS	TEMPERATURE CLASS	EQUIPMENT PROTECTION LEVEL

PACKAGING

CODE	WEIGHT		PACKAGING		
	KG	LBS	MM	INCH	PCS/BOX
FO0391010	25	55	240X400X350	10X16X15	1
FO0391020	25	55	240X400X350	10X16X15	1
FO0391310	32	70	400X600X430	16X24X17	1



FILTRATION



TANK MONITORING



HOSE REEL



ACCESSORIES



MERCHANDISE

PIUSI

B

ANY BIODIESEL

A

AIR

A

ANTIFREEZE

Ad

AdBlue®

B

BIODIESEL

D

DIESEL

F

FOOD

G

GASOLINE

G

GREASE

K

KEROSENE

O

OIL

W

WATER

W

WINDSCREEN

CHART

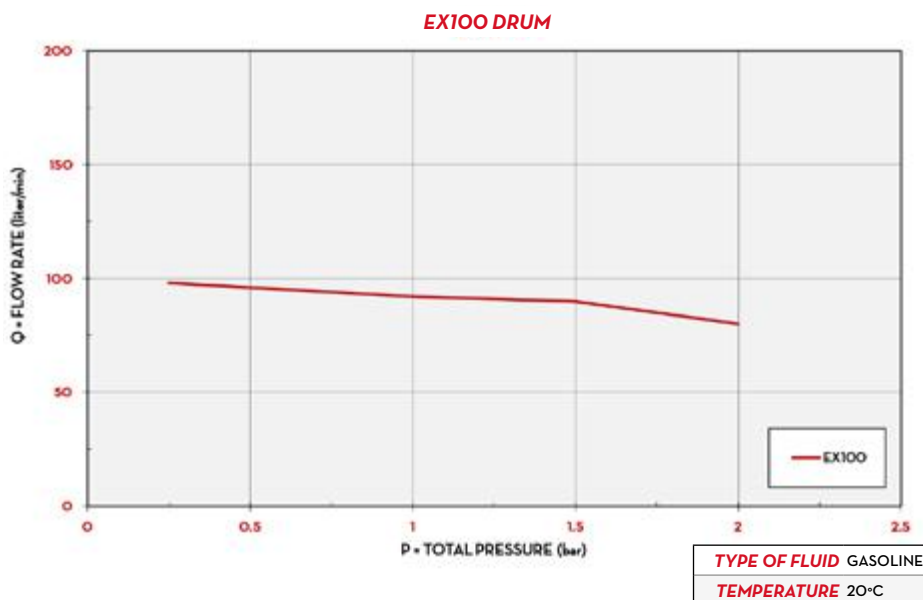

DIMENSIONS

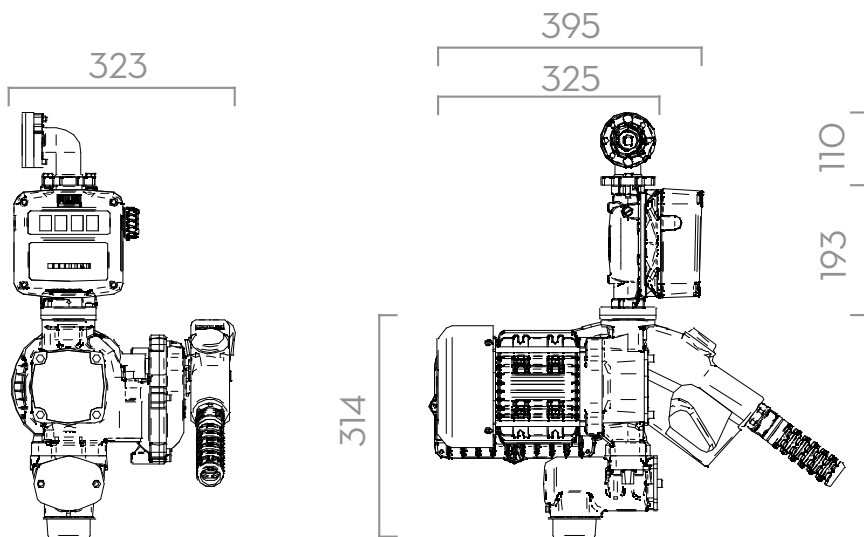

Dimensions expressed in millimeters

IN THE BOX

- EX100 PUMP
- NOZZLE HOLDER
- 2" TANK CONNECTOR
- 90° FLANGED ELBOW
- K150 ATEX METER (ON SELECTED VERSION)
- A140 ATEX AUTOMATIC NOZZLE (ON SELECTED VERSION)
- DELIVERY HOSE (ON SELECTED VERSION)
- INSTRUCTION MANUAL

DETAILS



MESH STRAINER



2" TANK CONNECTOR



90° FLANGED ELBOW



BENDING PROTECTION

COMPONENTS

- PUMP:
EX100
- METER:
K150 ATEX
- NOZZLE:
A140 ATEX

TECHNICAL DATA

CODE	DESCRIPTION	FLUIDS TYPE	FLOW RATE		VOLTAGE			DUTY CYCLE CONTINUOUS	INLET	OUTLET	METER	DELIVERY HOSE	BENDING PROTECTION	ULTRA HI-FLOW AUTO NOZZLE
			L/MIN	GPM	AC V./HZ	POWER WATT	AMP. MAX.							
FOO391010	(EX) EX100 DRUM 230V/50HZ (PUMP ONLY)	D G K	100	25	230/50	1035	4,5	YES	2" BSP	1" BSP	-	-	-	-
FOO391020	(EX) EX100 DRUM 230V/60HZ (PUMP ONLY)	D G K	100	25	230/60	874	3,8	YES	2" BSP	1" BSP	-	-	-	-
FOO391310	(EX) EX100 DRUM 230/50 /A140/K150/5MT	D G K	100	25	230/50	1035	4,5	YES	2" BSP	1" BSP	K150	D.25 5MT	YES	A140

() UPON REQUEST IT IS AVAILABLE WITH DIFFERENT VOLTAGES AND 60 HZ FREQUENCY. COMPATIBLE FLUIDS: DIESEL, KEROSENE, PETROL, PETROL ALCOHOL MIXED MAX 15%, ASPEN 2/4

ATEX KITS