



CUBE B.SMART

FEATURES

- STURDY STRUCTURE
- COMPACT DESIGN
- NATIVE WITH B.SMART CLOUD SOFTWARE
- KIT UPGRADE 1.0/2018 AVAILABLE
- IP55

The CUBE B.SMART fuel dispenser, available in the 70 and 90 litre/min versions with both AC and DC supply, is equipped with a self-priming vane pump with built-in bypass that ensures high performance. The anti-vibration support of the diesel dispenser guarantees silent operation and practicality, while the mechanical seal and the thermal protection of the induction motor against overheating make the product reliable and safe. CUBE B.SMART is equipped with an automatic nozzle with swivel connection. The installation of the mesh filter on the suction side ensures the pump longevity, as it prevents foreign bodies from ending up in the rotor and causing a blockage and consequent damage.

PERFORMANCE

UP TO 90 L/MIN	AC/DC
FLOW RATE	VOLTAGE
± 0,5%	BLUETOOTH
ACCURACY	CONNECTION



PACKAGING

CODE	WEIGHT		PACKAGING			N. BOXES / EUROPALLET	
	KG	LBS	MM	INCH	PCS/BOX	✕	🚛
FO0598000	24	53	380X380X480	15,0X15,0X18,9	1	-	-
FO0598010	24	54	380X380X480	15,0X15,0X18,9	1	-	-
FO0598A1A	20	44	380X380X480	15,0X15,0X18,9	1	-	-
FO0598AOA	20	44	380X380X480	15,0X15,0X18,9	1	-	-



FILTRATION



TANK MONITORING



HOSE REEL



ACCESSORIES



MERCHANDISE

PIUSI

BIS

ANY BIODIESEL

A

AIR

A

ANTIFREEZE

Ad

AdBlue®

B

BIODIESEL

D

DIESEL

F

FOOD

G

GASOLINE

G

GREASE

K

KEROSENE

O

OIL

W

WATER

W

WINDSCREEN

CHART

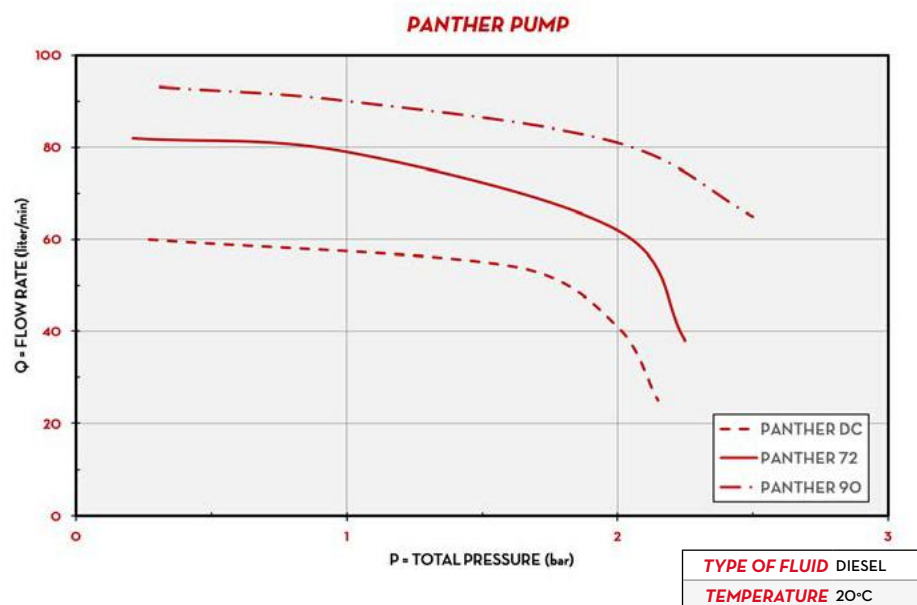

DIMENSIONS

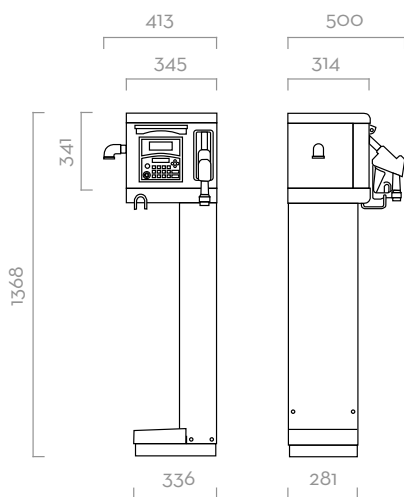

Dimensions expressed in millimeters

IN THE BOX

- CUBE B.SMART DISPENSER
- AUTOMATIC NOZZLE
- DELIVERY HOSE
- DRIVER ACCESS ADD-ON
- INSTRUCTION MANUAL

DETAILS



SHUTTER



B.SMART MOBILE APP

B.SMART

B.SMART CLOUD SOFTWARE

MATERIALS

- **PUMPS:**
PANTHER AC
PANTHER DC
- **METER:**
K600/3
- **NOZZLE:**
AUTOMATIC NOZZLE

TECHNICAL DATA

CODE	DESCRIPTION	FLUIDS TYPE	FLOW RATE		VOLTAGE			PUMP	METER	NOZZLE	FILTER	INLET	HOSE		
			L/MIN	GPM	AC V./HZ	DC VOLT	POWER WATT						AMP. MAX.	TYPE	LENGTH
FO0598000	CUBE 70 230V B.SMART 10 DIVERS	D	70	18	230 V	50 HZ	900 W	4,2 A	PANTHER 72	K600/3	A60	NO	1"	4M	25MM
FO0598010	CUBE 90 230V B.SMART 10 DIVERS	D	90	24	230 V	50 HZ	900 W	4,9 A	PANTHER 90	K600/3	A120	NO	1"	4M	25MM
FO0598A1A	CUBE 70 B.SMART 24V 10 ACCESS	D	70	18	24V	-	420W	25 A	PANTHER DC	K600/3	A70	NO	1"	4M	25MM
FO0598AOA	CUBE 12 V B.SMART · 10 DRIVERS	D	56	15	12 V	-	300W	35 A	PANTHER DC	K600/3	A60	NO	1"	4M	25MM